

Axcent 2 Fans



Safety, Installation, Operation and Maintenance Instructions

Part No. 502711

FläktWoods



SAFETY, INSTALLATION, OPERATION AND MAINTENANCE MANUAL

SECTION 1:	SAFETY
SECTION 2:	UNPACKING
SECTION 3:	STORAGE
SECTION 4:	INSTALLATION (MECHANICAL) FIGURE 1: ASSEMBLY DETAILS FIGURE 2: ASSEMBLY DETAILS
SECTION 5:	INSTALLATION (ELECTRICAL) AND OPERATION FIGURE 3: CONNECTION DIAGRAMS
SECTION 6:	SWITCH-ON
SECTION 7:	MAINTENANCE
SECTION 8:	OVERHAUL/EXTENDED MAINTENANCE
SECTION 9:	FAULT-FINDING
SECTION 10:	DISPOSAL

CONTACT ADDRESS:
FLÄKT WOODS LTD
AXIAL WAY,
COLCHESTER CO4 5ZD, UK.
Tel: +44 (0) 1206 222555
Fax: +44 (0) 1206 222777
Email: info@flaktwoods.com
Website: www.flaktwoods.com

DOCUMENT PART No 502711
ISSUE: APRIL 2001

1. SAFETY

WARNING

ONLY APPROVED, QUALIFIED PERSONNEL FAMILIAR WITH THE ASSESSMENT OF HAZARDS AND RISKS ASSOCIATED WITH FANS, AND WITH THE USE OF TOOLS AND TEST EQUIPMENT REQUIRED TO SERVICE SUCH FANS, SHOULD INSTALL, OPERATE AND MAINTAIN THE PRODUCT.

IF THE INSTALLER OR USER IS UNABLE TO UNDERSTAND THE INFORMATION IN THIS MANUAL, OR HAS ANY DOUBT THAT A SAFE AND RELIABLE INSTALLATION, OPERATION AND MAINTENANCE OF THE EQUIPMENT CAN BE ASSURED, FLÄKT WOODS OR THEIR REPRESENTATIVE SHOULD BE CONTACTED FOR ADVICE.

ALL WARNING AND SAFETY INFORMATION CONTAINED IN THIS DOCUMENT SHOULD BE READ BEFORE WORKING ON THE FAN ASSEMBLY.

- 1.1 Fläkt Woods fan assemblies are highly efficient air movement products designed and manufactured to standards and documentation that ensures all possible perceived hazards are assessed and eradicated before delivery to a customer. The fan is designed to operate with an airflow temperature of between -18°C and $+80^{\circ}\text{C}$ at up to 95% relative humidity. The motor operating temperature is between -30° to $+40^{\circ}\text{C}$ (-20° to $+40^{\circ}\text{C}$ on starting). When operating at low temperatures ice formation on the fan assembly must be prevented. Each fan assembly is delivered with a Declaration of Conformity that should be retained with the fan.

- 1.2 The fan assembly is manufactured specifically to fulfil a particular application/environment. No deviation from the original requirement should be implemented without referring to Fläkt Woods Limited. Should a fan failure occur whilst the product is under warranty, the Fläkt Woods service centre should be contacted, and supplied with full fan nameplate details, before any repair work is undertaken.

2. UNPACKING

- 2.1 On receipt of the fan assembly check that it is as ordered. Before fully unpacking the fan check that it has not been damaged during transit (bent flanges, deformed duct, damaged motor/guards/impeller etc). When unpacking to gain access to the fan, care should be taken to avoid injury from sharp edges, burrs, nails, staples, splinters etc. The fan packaging should be considered as a protective device only.

3. STORAGE

WARNING

WHEN FANS ASSEMBLIES ARE RETAINED IN STORAGE, ACCESS BY UNAUTHORISED PERSONS MUST BE PREVENTED WITH THE USE OF GUARDS, BARRIERS OR SECURE PREMISES SUCH THAT FAN IMPELLERS THAT MAY BE ROTATING (WINDMILLING) DO NOT PRESENT A HAZARD.

- 3.1 A fork-lift truck or similar should be used for moving the fan assembly into storage. The fan assembly can be heavy (between 78 and 940kg depending on fan and motor size, with additional ancillary equipment such as the silencer weighing up to 430kg and the diffuser weighing up to 143kg), and sometimes unwieldy (centre of gravity not central), and should be lifted slowly to prevent damage and distortion. The stored fan assembly must not have equipment stacked on it, and it must not be stacked on other equipment. The packaging must not be used as a lifting device unless otherwise indicated. The fan should be stored in a safe, clean, dry, vibration-free location. A regular monthly rapid spin of the impeller is recommended to prevent grease hardening and possible brinelling of the bearings; the impeller should not be in the same angular position after rotation.
- 3.2 If the fan is to be stored for 12 months or more, an inspection by Fläkt Woods service centre before installation is advised.

4. INSTALLATION (MECHANICAL)

WARNING

IT IS RECOMMENDED THAT SUITABLE SAFETY GUARDS (INLET, OUTLET AND BELT) FORM PART OF THE INSTALLATION WHEREVER NECESSARY. SUCH DEVICES, AND ADVICE ON SAFETY DEVICES, ARE AVAILABLE FROM FLÄKT WOODS.

WHERE THE FAN ASSEMBLY IS DELIVERED PACKAGED, THE PACKAGING MUST BE CONSIDERED AS A PROTECTIVE DEVICE ONLY, AND MUST NOT BE USED AS A LIFTING AID UNLESS OTHERWISE INDICATED.

ALL LIFTING AIDS AND LIFTING POINTS USED DURING INSTALLATION SHOULD BE ADEQUATELY CERTIFIED TO CARRY THE WEIGHT OF THE EQUIPMENT BEING LIFTED AND ITS 'SNATCH' WEIGHT. DURING LIFTING ALL PERSONNEL MUST BE CLEAR OF THE AREA BELOW THE SUSPENDED FAN.

BEFORE ENTERING THE AREA ENSURE THAT THE ENVIRONMENT IS SAFE TO EFFECTIVELY WORK IN, THAT ANY FUMES, DUST, TOXIC EMISSIONS, AND ENVIRONMENTAL HAZARDS ETC., HAVE BEEN REMOVED, AND THAT THE FAN BLADES ARE NOT LIKELY TO WINDMILL.

ALWAYS WEAR APPROPRIATE PROTECTIVE CLOTHING (INCLUDING HARNESSSES, HARD HATS, EYE PROTECTORS, GLOVES, BOOTS AND EAR DEFENDERS) WHEN WORKING IN THE VICINITY OF THE FAN ASSEMBLY.

4.1 General

- 4.1.1** Before installing the fan assembly, check that it has not been damaged in transit/storage (bent flanges, deformed duct, damaged motor(s)/guards/impeller etc), that the impeller rotates freely, and that the fan and motor nameplate data comply with the requirement of its use. If the fan assembly has been stored, the resistance of the motor windings to earth, should be measured (at 500V d.c). If any reading is less than ten megohms the motor should be dried in a warm air-flow and re-checked before it is switched on.
- 4.1.2** The fan assembly can be heavy (between 78 and 940kg depending on fan and motor size, with additional ancillary equipment such as the silencer weighing up to 430kg and the diffuser weighing up to 143kg), it could be unwieldy (centre of gravity not central), and so should be lifted slowly to prevent damage and distortion. If special lifting points are provided they must be used. Proper precautions must be taken, and certified lifting aids used, to ensure the fan is well supported and stable before lifting into position. Flange holes, lifting lugs or mounting feet holes, can be used for lifting but more than one hole must be used to safely spread the load. Strops can be wound round the fan duct to assist in the lifting process. The impeller must not be used to lift the fan. Any fixings disturbed during installation must be re-secured to their original torque value. The fan must be installed, such that it is squarely positioned in accordance with the airflow direction requested when the fan was ordered. The fan can be installed horizontally, vertically or inclined. Packing shims can be used to ensure the fan is squarely in place. An airflow indication arrow is shown on the fan nameplate. Sharp bends in the ductwork close to the fan must be avoided. Adequate room must be allowed round the fan for safe inspection and future maintenance, and the environment must be safe for both the fan, and for personnel, with emergency escape procedures in place should they be necessary. Care must be taken to ensure that during extremes of wet and windy weather any ingress of water through the fan will not reach sensitive or hazardous areas within the building.
- 4.1.3** The component parts of the fan assembly, including ancillary and optional equipment, must be fully aligned before being bolted together so that no distortion or stress is placed on the equipment. Appropriate fixings, with the correct torque applied, must be used to secure the fan into position. If in doubt about the torque of a particular fixing contact Fläkt Woods for advice. The final position of the fan must be strong and rigid enough to take the weight of the fan and any other weight applied during installation. Vibration isolators, appropriate for the weight of the fan, are recommended in order that any vibration of the fan is isolated so that no resonant frequencies or vibrations are generated in surrounding fixtures. If vibration isolators are used, flexible connectors and flexible electrical conduit should also be used. The vibration isolators and flexible connectors must not be used to align fixing points that are clearly misaligned. If any component parts do not easily fit together the cause must be investigated and rectified.
- 4.1.4** Motors are fitted with a drain hole. The motor drain hole should be at the lowest point of the motor when it is installed. Plugs that cover the drain holes should either be removed entirely if condensation is liable to occur due to large variations in operating temperature, or removed periodically to allow any general build-up of condensation to drain away. The frequency of plug removal will be dictated by environmental conditions, a record should thus be kept.

4.2 Belt driven fans (belt tension)

- 4.2.1** Before installing the fan ensure that the drive belt is in place and is correctly tensioned. Check the belt tension by exerting a force at the centre of the belt to obtain a deflection of 16mm per metre of span. The force required to achieve this deflection on the different types of belt is as follows (see also Section 6.3 and Table 1 Item 6).

Belt Type	Small Pulley Diameter (mm)	Force for Deflection (kgf)
SPZ	67 - 95	1.0 to 1.5
	100 - 140	1.5 to 2.0
SPA	100 - 132	2.0 to 2.7
	140 - 200	2.8 to 3.5
Z	56 - 100	0.5 to 0.8

4.3 Fans supplied without motor and drive

4.3.1 To assemble a fan with a motor and drive not supplied by Fläkt Woods proceed as follows:

4.3.1.1 cut a hole in the motor closing plate to the size indicated by the motor-to-guard shaft seal,

4.3.1.2 ensure that the closing plate surface is clean and free from contamination. Adhere the shaft seal to the hole. Note that where a D225 Motor is being used a seal is not required,

4.3.1.3 assemble the closing plate and motor,

4.3.1.4 assemble the drive components and set the belt tension as detailed in Paragraph 4.2.

4.4 After installation all packing materials must be disposed of in accordance with Section 10.

FIGURE 1
Belt driven fan

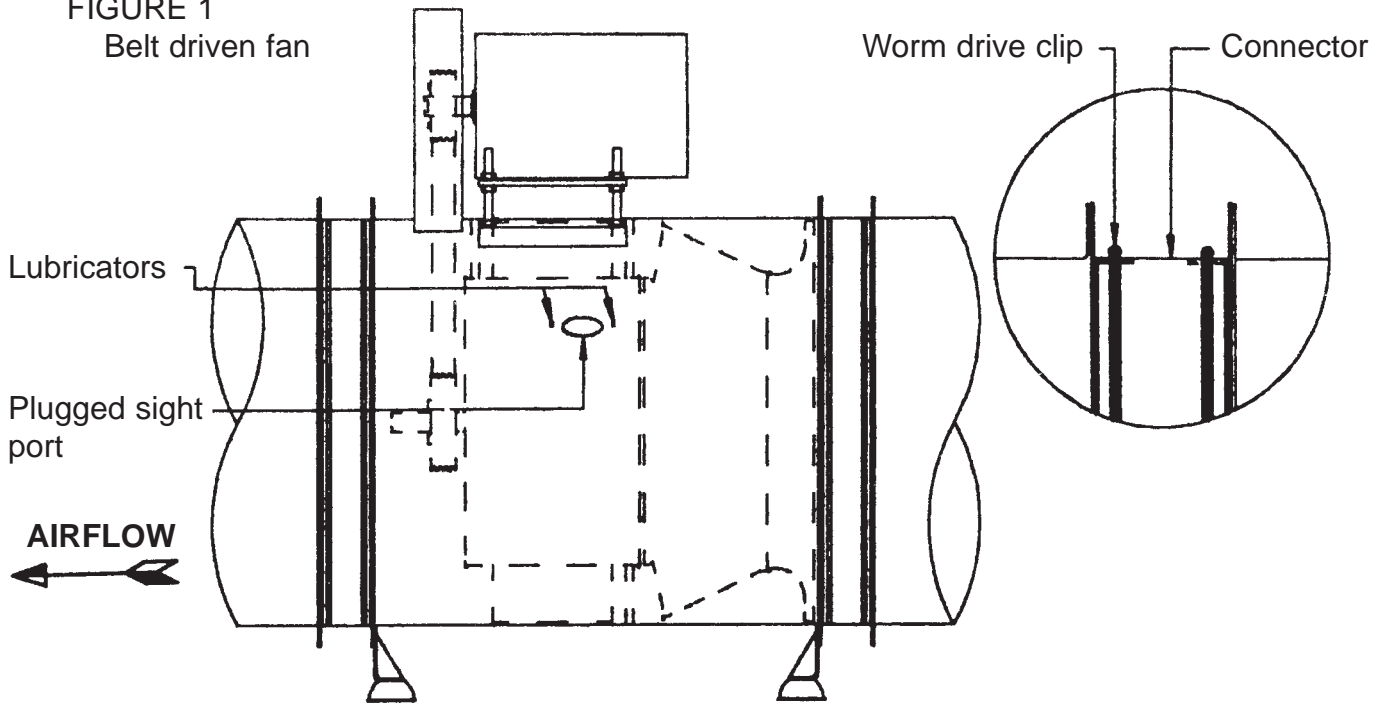

FIGURE 2
Fan mounted vertically

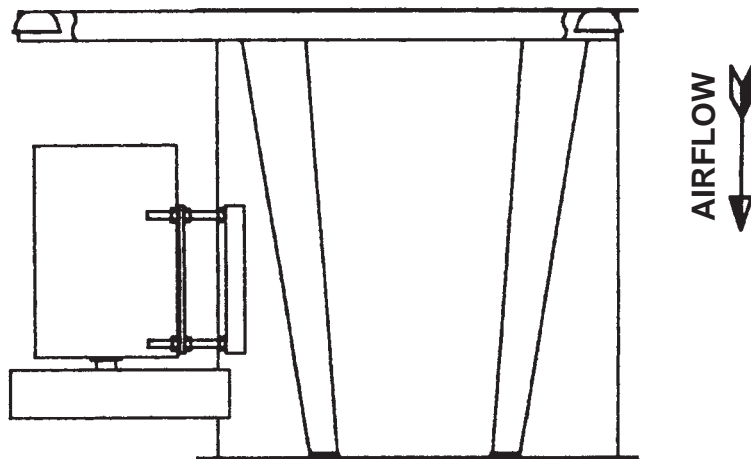

FIGURE 1

ASSEMBLY DETAILS

FIGURE 3
Fan mounted horizontally
with the motor off-set

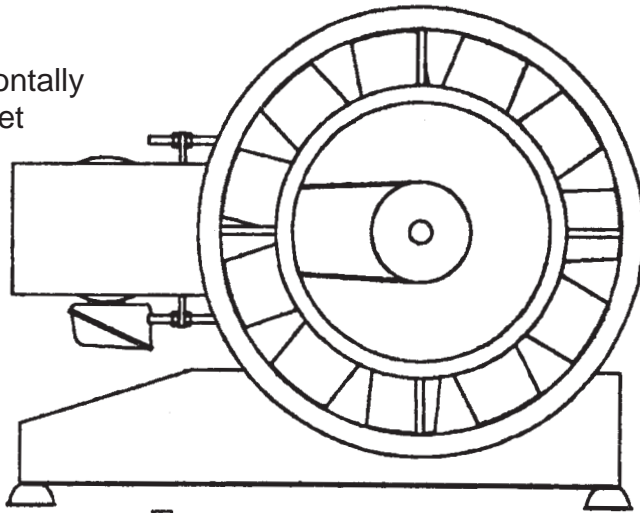
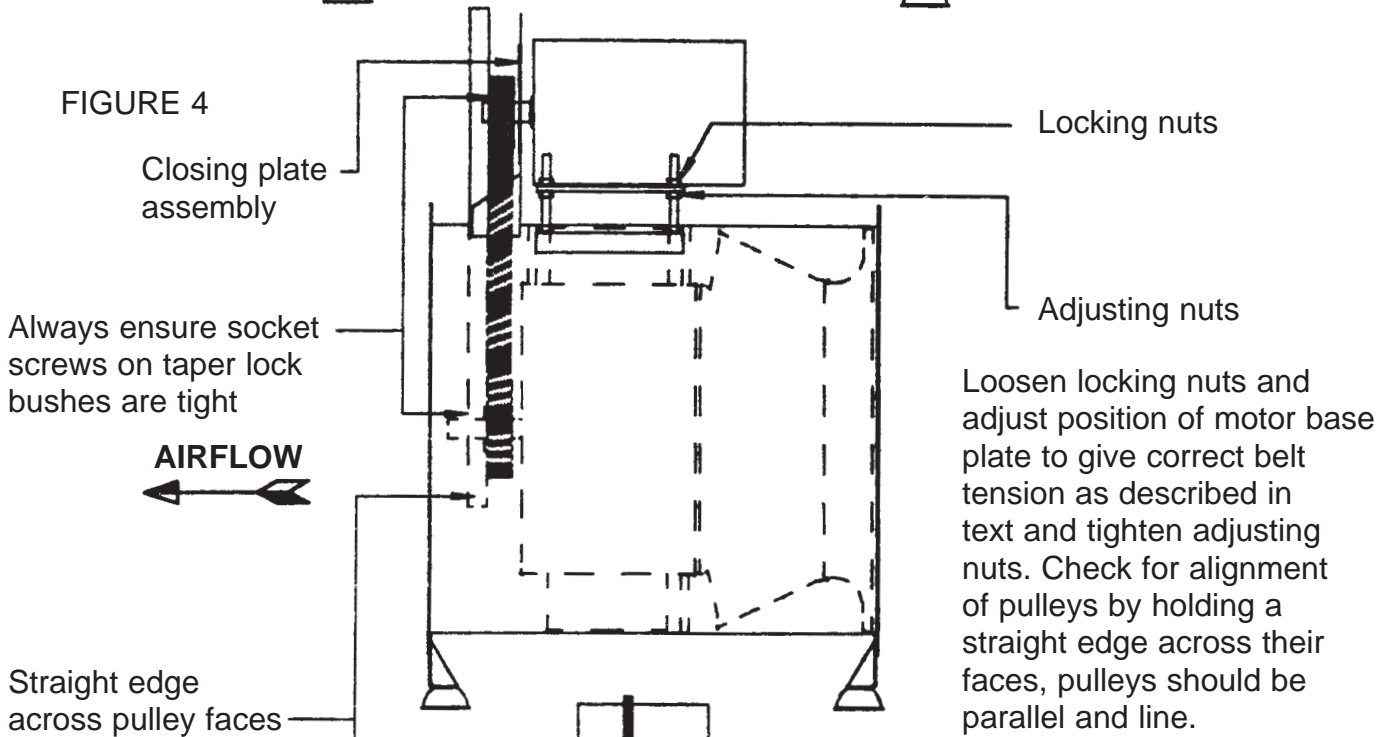

FIGURE 4



Straight edge
across pulley faces

Loosen locking nuts and
adjust position of motor base
plate to give correct belt
tension as described in
text and tighten
adjusting nuts. Check for alignment
of pulleys by holding a
straight edge across their
faces, pulleys should be
parallel and line.

FIGURE 5

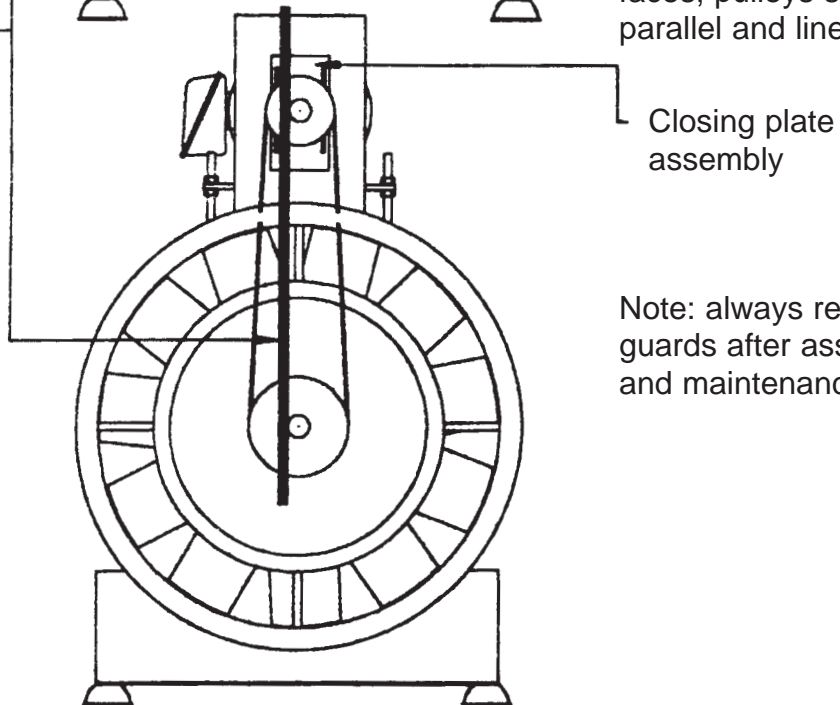

Note: always replace
guards after assembly
and maintenance work.

ASSEMBLY DETAILS

FIGURE 2

5. INSTALLATION (ELECTRICAL) AND OPERATION

WARNING

THE FAN ASSEMBLY CONTAINS ROTATING PARTS AND ELECTRICAL CONNECTIONS WHICH CAN BE A DANGER AND CAUSE INJURY. IF THERE IS ANY DOUBT THAT A SAFE AND RELIABLE INSTALLATION OF THE FAN CAN BE ASSURED; Fläkt Woods OR THEIR REPRESENTATIVE SHOULD BE CONTACTED FOR ADVICE.

IF THE FAN ASSEMBLY IS DESIGNED FOR HIGH-TEMPERATURE EMERGENCY USE; IT IS IMPERATIVE THAT THE WIRING USED IS HIGH TEMPERATURE RATED, AND THAT ALL SWITCHES AND CONTROLS ARE ABLE TO BE OVERRIDDEN DURING AN EMERGENCY OPERATION.

IF THE FAN STOPS DUE TO AN OVERHEAT SITUATION, THE OVERHEAT PROTECTION THERMOSTAT (IF FITTED - SEE SECTION 5.3) MAY RESET AS THE TEMPERATURE COOLS AND AUTOMATICALLY RESTART THE FAN IF POWER IS STILL APPLIED.

ALWAYS WEAR APPROPRIATE PROTECTIVE CLOTHING (INCLUDING HARNESES, HARD HATS, EYE PROTECTORS, BOOTS, GLOVES AND EAR DEFENDERS) WHEN WORKING IN THE VICINITY OF THE FAN ASSEMBLY.

5.1 General

- 5.1.1** The fan assembly is fitted with a terminal box on the motor. The electrical mains supply to the fan assembly should be connected into the terminal box through a weatherproof seal by an appropriately qualified electrician. Any unused entry points into the terminal box must be sealed. Connection details are provided with the fan assembly; additional information is provided in the connection diagrams that form part of this document (see Figure 3). It is good practice to fit a clearly-marked lockable isolator switch close to the fan, and have a clearly-marked and accessible push button stop/start switch on a control panel located remotely from the fan. The two switches allow safe control of the fan, provide a means of safely isolating the fan (until a controlled restart is made); they protect personnel during maintenance, during a fault situation, or during a mains failure/fluctuation. A suitable earth must also be connected. Sufficient cable length should be provided to allow for the flexibility of the fan on its vibration isolators (if fitted).
- 5.1.2** Fuses and wiring in the fan electrical control circuit must be sufficiently rated to carry the fan starting current as indicated on the motor nameplate. Fuses should be regarded as only protecting the wiring against the effects of short circuits or earth faults; they are not suitable for overload protection. To provide full protection for the motor, a control panel with overload protectors should be used. Overload protectors should be rated 15% above the motor full load current indicated on the motor rating label.
- 5.1.3** If a speed controller, or other controlling equipment, forms part of the system it should be able to control the fan within safe limits. Sufficient fan speed must be maintained to open any shutters that may be in the air-flow. The controlling equipment should be securely located, and should not be, or cause, a radiation hazard. Fläkt Woods can be contacted for advice on all forms of control equipment supplied by the Company.
- 5.1.4** Speed controllers should not be used without prior agreement with Fläkt Woods.

5.2 Capacitors (single-phase motors only)

- 5.2.1** Capacitors are mounted on the motor during manufacture. Larger rated capacitors are supplied separately and must be fitted externally from the motor. Capacitors for flameproof motors must be located outside the hazardous area.

5.3 Overheat Protection

5.3.1 Motor overheat protection (if fitted) can be fitted on all single-phase and three-phase motors. Overheat protection is achieved by the use of either thermostats or thermistors. The protection devices are wired in either of the following two ways:

5.3.1.1 on single-phase and three-phase motors with a full load current of up to and including 6.3A:

thermostats are wired in series with the motor winding; they operate by opening and closing with temperature to automatically open circuit the winding and stop the fan in an overheat situation (see Section 5 Warning). On cooling the motor will automatically re-start, however on single-phase motors of this type, manual re-start can be achieved by removing the link between terminals K and UZ and wiring terminals K – K directly to the motor start contactor,

thermistors are wired to separate terminals (S – S) within the terminal box; they change their resistive value with temperature and must be wired to control the motor start contactor via a suitable relay.

5.3.1.2 on single-phase and three-phase motors with a full load current above 6.3A:

thermostats are wired to separate terminals (K – K) within the terminal box; they operate by opening and closing with temperature and must be wired to directly control the motor start contactor,

thermistors are wired to separate terminals (S – S) within the terminal box; they operate by changing their resistive value with temperature and must be wired to control the motor start contactor via a suitable relay.

Note that when the motor cools the thermostat will reset; the motor however must not be able to start until the motor start contactor is manually reset.

5.4 Fans with flameproof motors

5.4.1 Fans with flameproof motors are designed for use in locations where there are liable to be fumes, dust or flammable/explosive gases. Installation should be carried out by qualified personnel. Special care must be exercised when electrically connecting such units to ensure that a secure flameproof connection is achieved. Great care must be taken to ensure that the thread of cable glands, or conduit, matches the thread into which it is screwed, and that the correct sealant is used wherever necessary so that the entire installation achieves the flameproof barrier required. Any electrical control gear (including the start capacitor in the case of single-phase motors) must be located outside the hazardous area if they are not of a flameproof type. The motor should not be allowed to become coated with dirt/dust, etc. which could restrict surface cooling and consequently raise the temperature of the motor carcass. If in doubt about the achievement of the flameproof barrier contact Fläkt Woods Service Centre for advice.

STAR. DIRECT-ON LINE OR AUTOTRANSFORMER STARTING

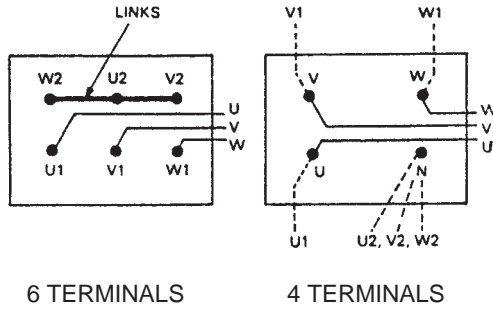

6 TERMINALS

4 TERMINALS

DELTA. DIRECT-ON LINE OR AUTOTRANSFORMER STARTING

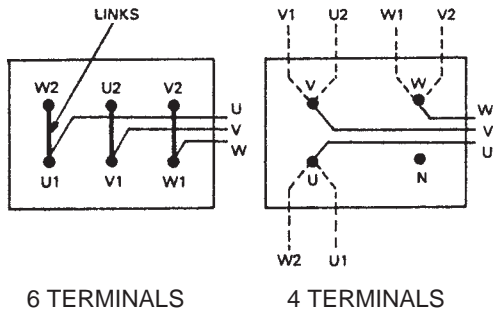

6 TERMINALS

4 TERMINALS

STAR-DELTA STARTING

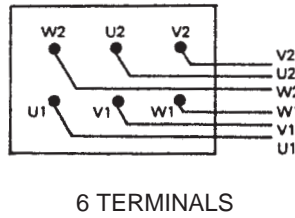

6 TERMINALS

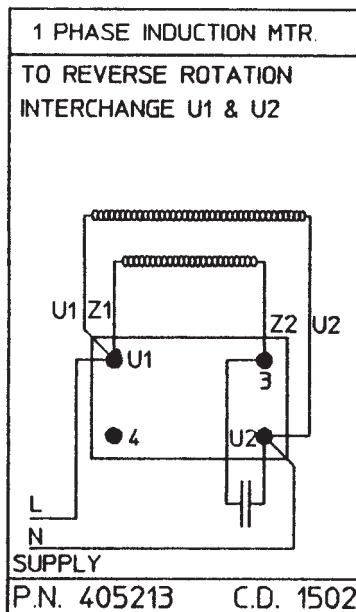

FIGURE 3

CONNECTION DIAGRAMS

6. SWITCH-ON

- 6.1** Only appropriately qualified personnel should switch-on the fan. Before switching on confirm that the electrical supply is fully compliant with the requirement of the motor as detailed on the motor nameplate. Ensure that the fan is correctly installed, all component parts and fixings are secure, safety guards are in place, no loose articles are present in the vicinity, that any temporary device used to stop the fan blades windmilling has been removed, and that personnel present are aware of the noise/vibration aspects of a fan starting and running and that they may not be able to communicate effectively with each other.
- 6.2** Immediately on switch-on check the assembly for smooth, low-vibration running, that the current consumption is within the full load current specified on the nameplate, and that the motor is not getting excessively hot. A trial connection of the three-phase supply should be made to check that the fan rotates in the required direction. If the rotation is incorrect interchange any two phases of the incoming supply at the motor terminal block. If after correctly connecting the single-phase supply the fan is found to be rotating in the wrong direction, the motor winding leads U1 and U2 should be interchanged at the motor terminal block. The fan must not be switched on and off in a manner that could cause overheating of the motor, or could damage the insulation of the motor and the wiring to the motor.
- 6.3** After two hours of initial running, and again after three months, re-check the tension of the belt in accordance with Paragraph 4.2 and adjust it if necessary. Check that the belt is not dirty, wet, polluted; or is overheating. If there is dirt, excessive moisture or pollutants in the airflow an internal guard should be fitted to protect the belt, and the external guard should be of a ventilated type to provide cooling. When the fan is used to handle clean air no internal belt guard is necessary and the external belt guard is sealed.
- 6.4** Shutdown of the fan should be made in a controlled manner, and the system left safe and secure particularly if maintenance is to be carried out.

7. MAINTENANCE

WARNING

NO MAINTENANCE WORK SHOULD BE ATTEMPTED BEFORE SWITCHING OFF AND COMPLETELY ISOLATING THE FAN ASSEMBLY, AND ITS CONTROLS, FROM ALL ELECTRICAL SUPPLIES AND ALLOWING THE ROTATING PARTS OF THE FAN TO COME TO REST, THE MOTOR TO COOL, AND ANY CAPACITORS TO DISCHARGE.

BEFORE ENTERING THE AREA ENSURE THAT ALL FUMES, DUST, TOXIC EMISSION, HEAT ETC HAVE DISPERSED FROM THE LOCAL ENVIRONMENT, AND THAT THE FAN BLADES ARE NOT LIKELY TO WINDMILL.

ALL LIFTING AIDS USED DURING MAINTENANCE, AND ALL LIFTING POINTS UTILISED, SHOULD BE ADEQUATELY CERTIFIED TO CARRY THE WEIGHT OF THE EQUIPMENT BEING LIFTED.

ALWAYS WEAR APPROPRIATE PROTECTIVE CLOTHING (INCLUDING HARNESSSES, HARD HATS, BOOTS, EYE PROTECTORS AND EAR DEFENDERS) WHEN WORKING IN THE VICINITY OF THE FAN ASSEMBLY.

NOTE: *The maintenance procedures are designed to keep the fan equipment safe, operational and fault-free.*

7.1 Maintenance must be carried out on the fan assembly by experienced and appropriately qualified personnel using the correct tools and equipment. A regular routine maintenance schedule should be established to keep the fan assembly safe, operational and fault-free; and a record must be kept. A list of suggested intervals is given in Table 1. Where the environment is particularly dirty, a reduction in the intervals may be necessary. Internal and external fan and motor surfaces may be cleaned with low pressure clean water and non-abrasive additives. Direct application of water from any direction to the motor drain plugs, motor shaft seals and silencer in-fill must be avoided. No toxic materials should be used in the enclosed area of the fan.

7.2 It is essential to ensure that all fixings on the assembly are secure. When examining and checking the security of fixings during routine maintenance (see the following torque list and Table 1, Items 8 and 9), those fixings that are locked into position in any way or are painted over, need not be disturbed if they can be seen to be secure. Any locking devices that are disturbed during maintenance must be discarded and replaced with identical devices. Thread forming screws must have locking compound applied when being reused. Information on replacement locking devices, and parts of all types, is available from Fläkt Woods. Those fixings that have no locking devices fitted and are torqued into position, should be checked at 95% of their original setting to ensure no un-necessary disturbance of the fixing. If in doubt about the torque of a particular fixing contact Fläkt Woods for advice. Additional care must be observed when disturbing fixings that secure devices that hold potential energy in place (eg springs, anti-vibration mounts etc).

ASSEMBLY TORQUE Nm.				
SIZE	IMPELLER FIXING.	NUT & BOLT (GR. 8.8)	NUT ON MILD STEEL STUD.	SCREW IN TSN NUTSERT.
M5	4.0	—	—	—
M6	—	11.7	—	11.7
M8	10.0	28.0	—	—
M10	20.0	56.0	28.0	—
M12	36.0	98.0	49.0	—
M16	91.0	244.0	122.0	—
M20	178.0	476.0	138.0	—
M24	—	—	411.0	—

7.3 Impeller running clearances must be periodically checked (see the following list (in mm)/diagram; and Table 1 Item 7) to ensure safe operation of the fan.

SIZE	A	B	C
315	2.65	1.2	2.50
400	2.50	2.4	3.25
500	3.50	3.8	4.00
630	3.85	5.6	5.00
800	4.00	6.9	6.00
1000	4.25	7.4	7.00
1120	4.50	9.7	8.00
1250	5.00	12.0	9.00

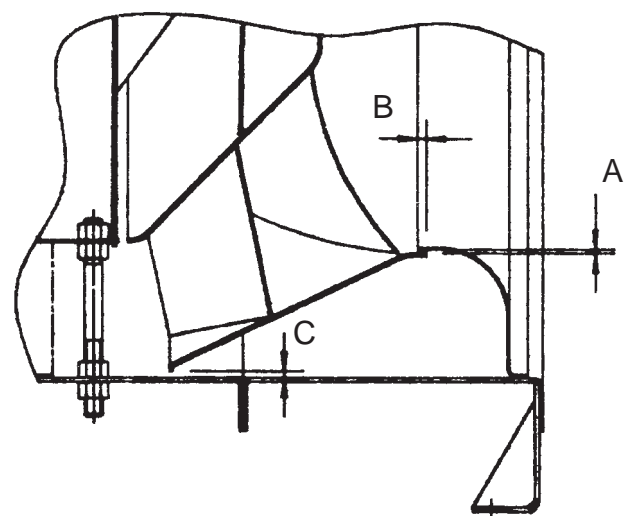

7.4 In addition to routine maintenance, motor bearings, if they are not of the sealed type, will require attention (see Table 1 Item 12). If the motor bearings are greased through lubricators, the grease should be periodically applied in accordance with the instructions on the fan or motor nameplate. A

compatible grease type must be used. It is essential that every trace of water and dirt is removed from around the grease points and that a clean grease gun is used. Only low pressure should be needed to inject the specified quantity of grease. If a high pressure is required, the cause should be investigated. Grease points are generally located in the region of the duct terminal box. The impeller shaft bearing will also require greasing periodically (see the following list and Table 1 Item 12). with Unirex N3 or similar.

Fan Size	Bearing Grease ml	Housing Quantity ln ³	Re - lub period (yrs)
315	5.0	0.30	2
400	7.0	0.45	2
500	9.0	0.56	2
630	10.0	0.63	2
800	14.0	0.88	2
1000	14.5	0.90	1
1120	14.5	0.90	1
1250	22.0	1.34	1

7.5 After maintenance ensure that no loose articles are present in the vicinity of the fan, that all safety guards are properly secured into their original location, and that any temporary device used to stop the fan blades windmilling has been removed.

7.6 Infrequent Use

7.6.1 If the fan assembly is to be used less frequently than once a month, or for emergency-use only, the following two additional maintenance procedures should be carried out, and a record kept:

7.6.1.1 the resistance of the motor windings to earth should be measured (at 500V d.c) each month. If the reading is less than ten megohms, the motor should be dried in a warm air-flow (typically 40°C) and re-checked before running the motor,

7.6.1.2 the fan should be operated for at least two hours each month to ensure correct lubricant conditions in the bearings.

TABLE 1

	ROUTINE MAINTENANCE SCHEDULE	EVERY 6 MONTHS	EVERY 12 MONTHS	COMMENTS
1.	Examine the airways into the fan guards	*		Remove any debris that may have accumulated round the guards.
2.	Examine motor cooling fins.	*		Remove any material/dirt build-up between the motor fins.
3.	Examine impeller for dirt build-up and for any physical damage.	*		Remove any build-up of dirt. Ensure impeller-fixing screw is securely torqued into position. Replace impeller if it is damaged.
4.	Examine condition of 'inlet', 'outlet' and 'belt' safety guards (if fitted) and their fixings.	*		Clean safety guards. Replace them if there are any signs of damage.
5.	Check operation of shutters (if fitted)	*		Ensure shutters are clean and that they open and close easily. Apply oil/grease to mechanism if necessary.

6.	Inspect the drive belt, its mechanism and guard (similarly check the standby motor assembly if fitted)	*		Ensure that the area is clean (see Section 6.3). Set the belt tension for a deflection (at the middle point of the belt) of 16mm per metre of span as detailed in Section 4.2. Belt and guard replacement information is available from Fläkt Woods.
7.	Examine the impeller running clearances. Check the security of the impeller.		*	Ensure that the impeller running clearances are correct (see Section 7.3). If in doubt about clearances contact Fläkt Woods Limited for advice. Ensure that the impeller is secure.
8.	Check torque of fan-to-support fixings.		*	It is essential to confirm that all fixings are properly fitted, are tight, and are fully driven home (see Section 7.2) . If in doubt about the torque of a fixing contact Fläkt Woods Limited for advice.
9.	Examine fan assembly fixings.		*	It is essential to confirm that all fixings are properly fitted, are tight, and are fully driven home (see Section 7.2) . If in doubt about the torque of a fixing contact Fläkt Woods Limited for advice.
10.	Check motor voltage and current consumption		*	Ensure voltage and full load current is as specified on the motor nameplate.
11.	Inspect paintwork/galvanising.		*	Treat any areas of damage or corrosion with suitable non-toxic anti-corrosion paint.
12.	Grease motor and impeller bearings		*	Refer to Section 7.4
13.	Check fan assembly wiring		*	Check security, and condition, of all wiring (including the earth).

8. OVERHAUL/EXTENDED MAINTENANCE

8.1 The procedures detailed in this document are designed to keep the fan assembly safe, operational and fault-free; however in the longer term the fan will require additional servicing that may include a complete overhaul, bearing/seal replacement, motor replacement, motor rewinding, spare parts, condition monitoring, vibration analysis, refurbishment, etc. Information on all aspects of overhaul/extended maintenance is available from Fläkt Woods service centre. After overhaul/extended maintenance the fan assembly must be safely and correctly installed back into its original position in accordance with this document.

9. FAULT-FINDING

9.1 Fault-finding must be carried out on the fan assembly by appropriately qualified personnel using the correct tools and equipment.

9.1.1 Electrical

9.1.1.1 Check that the electrical connections to the assembly are secure and wired in accordance with the circuit diagram,

9.1.1.2 Check that the voltage applied to the assembly is as specified on the motor nameplate and is balanced,

- 9.1.1.3** Connect an ammeter (clampmeter) in line with each phase (one phase in the case of single phase motors) of the motor in turn and check that the current consumption is within the full load current specified on the motor nameplate,
- 9.1.1.4** Measure each motor winding to earth, and between each winding, using a 500V d.c insulation tester. If the reading is less than ten megohms the reason is liable to be dampness in the motor. To 'dry the motor place it in a warm (typically 40°C) dry airstream and regularly monitor the motor until the insulation reading is restored to ten megohms or greater. If the reading remains less than ten megohms a break-down in the motor winding insulation could be the reason, and a motor rewind/overhaul may be necessary,
- 9.1.1.5** Ensure that there is no smell of burnt insulation in the vicinity of the motor.
- 9.1.2** **Mechanical**
- 9.1.2.1** Check that there is no obstruction to the motor impeller blade, that the blade is clean, and no loose articles or debris are present in the vicinity,
- 9.1.2.2** Rotate the motor shaft by hand. Investigate any sound of internal chaffing, rubbing or stiffness. Any stiffness may indicate that the bearings require lubrication or replacing,
- 9.1.2.3** Lift the end of the motor shaft if possible to check for bearing wear (i.e. excessive lift of shaft). Rotate the motor shaft by hand. Investigate any sound of internal chaffing or rubbing,
- 9.1.2.4** Ensure that all fixings are secure,
- 9.1.2.5** Check that the drive belt is not broken or slipping.

10. DISPOSAL

When the fan assembly has completed its working life the metal components should be segregated and recycled. The remaining items of material should be safely disposed of in accordance with local health and safety regulations.

We Bring Air to Life

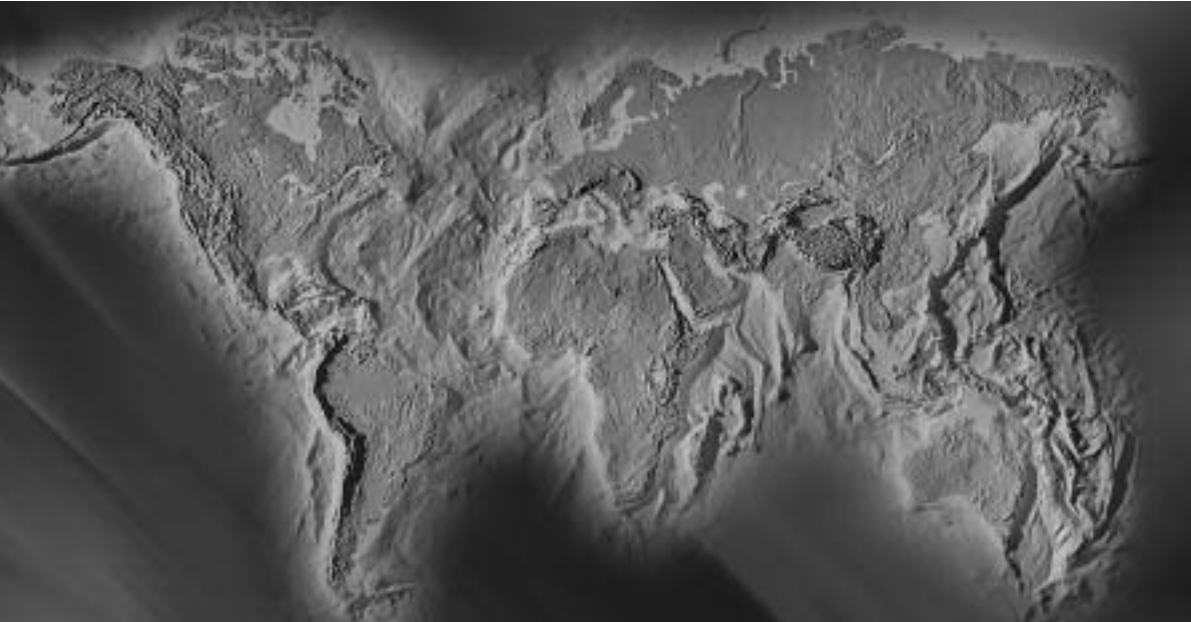

Fläkt Woods Group provides a full range of products and solutions for buildings ventilation, air treatment and industrial air movement

Sales Office

Fläkt Woods Ltd

Unit 6240, Bishops Court
Solihull Parkway
Birmingham
B37 7YB
Tel: +44 (0)121 717 4680
Fax: +44 (0)121 717 4699

Sales Office

Fläkt Woods Ltd

First Floor, Entrance 6,
Crossford Court
Dane Road, Sale, Cheshire
M33 7BZ
Tel: +44 (0)161 969 1992
Fax: +44 (0)161 969 4612

Head Office

Fläkt Woods Ltd

Axial Way
Colchester
Essex
CO4 5ZD
Tel: +44 (0)1206 222 555
Fax: +44 (0)1206 222 777

Sales Offices available World Wide - See our website for details

www.flaktwoods.com/uk

Due to a policy of continuous development and improvement the right is reserved to supply products which may differ from those illustrated and described in this publication. Certified dimensions will be supplied on request on receipt of order.

Copyright, Fläkt Woods Ltd. 2006.

All rights reserved. No part of this publication may be produced in any material form by any means without the written permission of Fläkt Woods Ltd. Any unauthorised use of this data may result in legal proceedings.

FWDD/O906/PN502711 (2001 edition)