

# Fläkt Woods FWX Range

3ph output

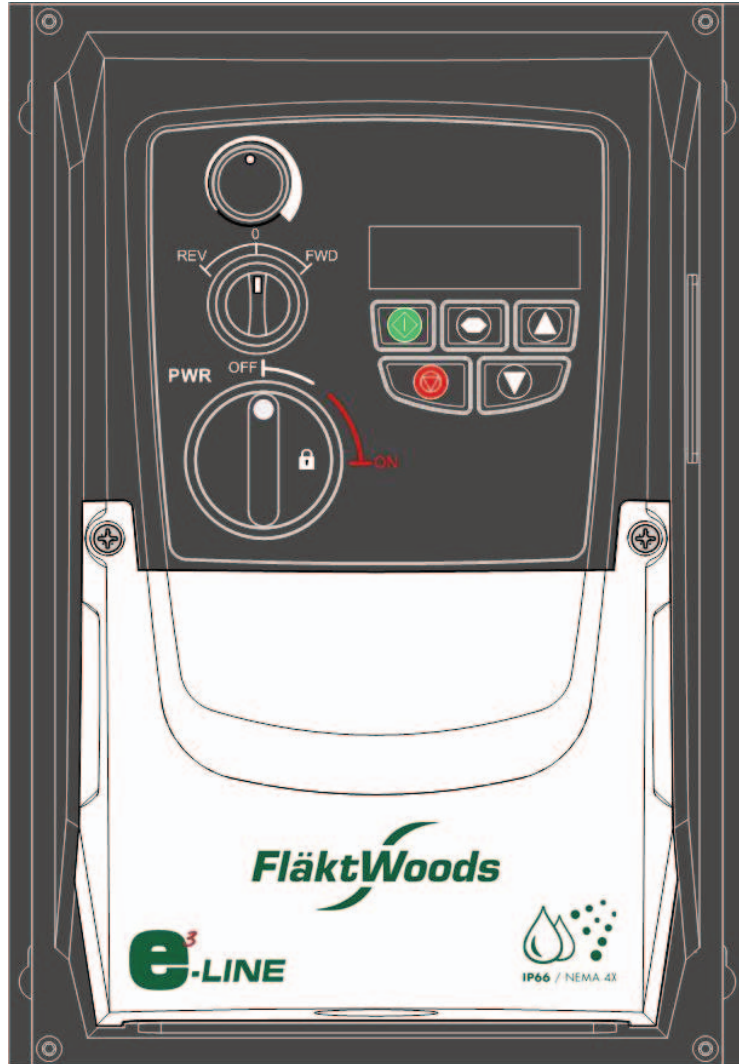

## *Safety, Installation, Operation and Maintenance Instructions*

Part No. 430478



Thank you for purchasing a Fläkt Woods FWX Drive. This device forms part of our e3Line range of energy efficient products. This document illustrates the installation and operation for speed control of the fan. In this booklet we have put together some simple instructions which we hope you will find easy to follow. We wish you every success, and hope you will use our equipment again in the future.

## Index

1.	<b>INTRODUCTION</b>	
1.1.	Important safety information	2
2.	<b>GENERAL INFORMATION AND RATINGS</b>	
2.1.	Identifying the drive by model number	3
2.2.	Drive model numbers	4
3.	<b>MECHANICAL INSTALLATION</b>	
3.1.	General	4
3.2.	Mechanical dimensions and mounting	5
3.3.	Gland Sizes & Lock off	5
3.4.	Removing the Terminal Cover	6
4.	<b>POWER WIRING</b>	
4.1.	Grounding the Drive	6
4.1.1.	Grounding Guidelines	6
4.2.	Wiring Precautions	6
4.3.	Drive and Motor Connections	7
5.	<b>OPERATION</b>	
5.1.	Managing the keypad	7
5.1.1.	Changing Parameters	8
5.1.2.	Reset Factory Default Settings	8
5.2.	Terminal Control	8
5.3.	Using the REV/O/FWD selector switch	8
5.4.	Standard Parameters	9
6.	<b>TROUBLESHOOTING</b>	
6.1.	Fault messages	10
7.	<b>TECHNICAL DATA</b>	
7.1.	Environmental	11
7.2.	Rating tables	11
8.	Easy start up guide:	11

## Declaration of Conformity:

Fläkt Woods Limited hereby states that the FWX product range conforms to the relevant safety provisions of the Low Voltage Directive 2006/95/EC and the EMC Directive 2004/108/EC and has been designed and manufactured in accordance with the following harmonised European standards:

EN 61800-5-1: 2003	Adjustable speed electrical power drive systems. Safety requirements. Electrical, thermal and energy.
EN 61800-3 2nd Ed: 2004	Adjustable speed electrical power drive systems. EMC requirements and specific test methods
EN 55011: 2007	Limits and Methods of measurement of radio disturbance characteristics of industrial, scientific and medical (ISM) radio-frequency equipment (EMC)
EN60529 : 1992	Specifications for degrees of protection provided by enclosures

## Electromagnetic Compatibility

All FWX drives are designed with high standards of EMC compliance in mind. All versions suitable for operation on Single Phase 230 volt and Three Phase 400 volt supplies and intended for use within the European Union can be fitted with an internal EMC filter. This EMC filter is designed to reduce the conducted emissions back into the supply via the power cables for compliance with harmonised European standards.

It is the responsibility of the installer to ensure that the equipment or system into which the product is incorporated complies with the EMC legislation of the country of use. Within the European Union, equipment into which this product is incorporated must comply with the EMC Directive 2004/108/EC. When using an FWX drive with an internal or optional external filter, compliance with the following EMC Categories, as defined by EN61800-3:2004 can be achieved:

Drive Type / Rating	EMC Category		
	Cat C1	Cat C2	Cat C3
1 Phase, 230 Volt Input FWX-2-x2xxx-xxBxx	No additional filtering required Use shielded motor cable		
3 Phase, 400 Volt Input FWX-2-x4xxx-xxAxx	Use External Filter OD-Fx34x	No additional filtering required	
	Use screened motor cable		
<b>Note</b>	For motor cable lengths greater than drive rated cable length, an output dv / dt filter must be used (part number OD-OUTFx, please refer to Fläkt Woods for further details)		

## Company Information

Address: Fläkt Woods Limited  
Axial Way  
Colchester  
Essex  
CO4 5ZD  
United Kingdom  
Email: info.uk@flaktwoods.com  
Website: www.flaktwoods.com

The manufacturer accepts no liability for any consequences resulting from inappropriate, negligent or incorrect installation, or adjustment of the optional operating parameters of the drive or from mismatching of the drive to the motor.

The contents of this User Guide are believed to be correct at the time of printing. In the interest of a commitment to a policy of continuous improvement, the manufacturer reserves the right to change the specification of the product or its performance or the contents of the User Guide without notice.

All Fläkt Woods FWX drives carry a 2-year warranty, valid from date of sale.

# 1. Introduction

## 1.1. Important safety information

This variable speed drive product is intended for professional incorporation into complete equipment or systems. If installed incorrectly it may present a safety hazard. The FWX uses high voltages and currents, carries a high level of stored electrical energy, and is used to control mechanical plant that may cause injury. Close attention is required to system design and electrical installation to avoid hazards in either normal operation or in the event of equipment malfunction.

System design, installation, commissioning and maintenance must be carried out only by personnel who have the necessary training and experience. They must carefully read this safety information and the instructions in this Guide and follow all information regarding transport, storage, installation and use of the FWX, including the specified environmental limitations.

Please read the IMPORTANT SAFETY INFORMATION below, and all Warning and Caution information elsewhere.



Indicates a potentially hazardous situation which, if not avoided, could result in injury or death.



Indicates a potentially hazardous situation which, if not avoided, could result in damage to property.

Safety of machinery, and safety-critical applications

The level of integrity offered by the FWX Drive control functions – for example stop/start, forward/reverse and maximum speed, is not sufficient for use in safety-critical applications without independent channels of protection. All applications where malfunction could cause injury or loss of life must be subject to a risk assessment and further protection provided where needed. Within the European Union, all machinery in which this product is used must comply with Directive 89/392/EEC, Safety of Machinery. In particular, the electrical equipment should comply with EN60204-1.



- FWX Drives should be installed only by qualified electrical persons and in accordance with local and national regulations and codes of practice. The FWX Drive has an Ingress Protection rating of IP66. For higher IP ratings, use a suitable enclosure
- Electric shock hazard! Disconnect and ISOLATE the FWX Drive before attempting any work on it. High voltages are present at the terminals and within the drive for up to 10 minutes after disconnection of the electrical supply.
- Where supply to the drive is through a plug and socket connector, do not disconnect until 10 minutes have elapsed after turning off the supply
- Ensure correct earthing connections. The earth cable must be sufficient to carry the maximum supply fault current which normally will be limited by the fuses or MCB
- The STOP function does not remove potentially lethal high voltages. ISOLATE the drive and wait 10 minutes before starting any work on it
- If it is desired to operate the drive at any frequency/speed above the rated speed of the motor, consult Fläkt Woods about suitability for over-speed operation
- The fan (if fitted) inside of the FWX Drive starts automatically when the heat sink temperature reaches approximately 45°C



- Carefully inspect the FWX Drive before installation to ensure it is undamaged
- Indoor Use Only
- Flammable material should not be placed close to the drive
- The entry of conductive or flammable foreign bodies should be prevented
- Relative humidity must be less than 95% (non-condensing)
- Ensure that the supply voltage, frequency and no. of phases (1 or 3 phase) correspond to the rating of the FWX Drive as delivered
- An isolator should be installed between the power supply and the drive
- Never connect the mains power supply to the Output terminals U, V, W
- Suitably rated fuses or MCB should be fitted in the mains supply to the drive
- Do not install any type of automatic switchgear between the drive and the motor
- Wherever control cabling is close to power cabling, maintain a minimum separation of 100 mm and arrange crossings at 90 degrees
- Integral solid state short circuit protection does not provide branch circuit protection. Branch circuit protection must be provided in accordance with the National Electrical Code and any additional local codes

## 2. General Information and Ratings

This chapter contains information about the FWX Drive including identification

### 2.1. Identifying the drive by model number

Each drive can be identified by its model number, as shown below.

Figure 1 Drive Model Number Format. The model number is on the shipping label and the drive nameplate. The model number includes the drive and any options.

Drive model numbers for the FWX Drive drives are provided in STET rating tables.

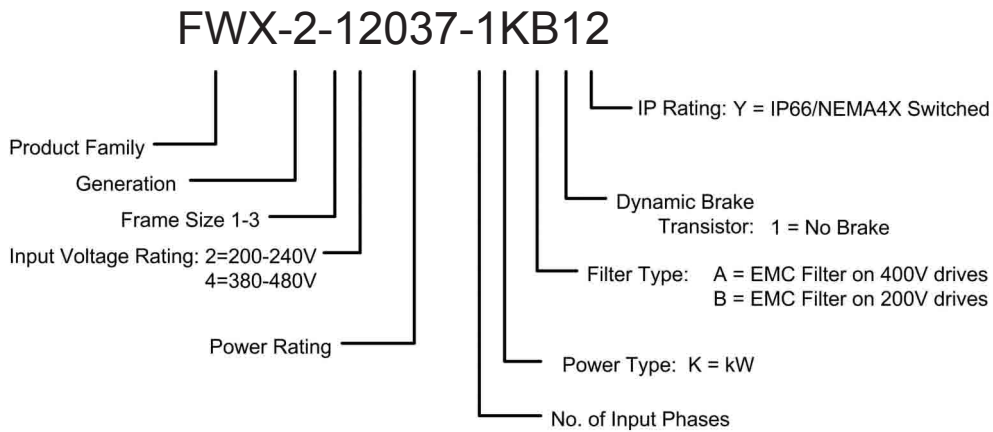

Figure 1 Drive Model Number Format

### 2.2. Drive model numbers

<b>200-240V ±10% - 1 Phase Input</b>				
<b>kW Model Number</b>		<b>Part Number</b>	<b>Output Current (A)</b>	<b>Frame Size</b>
<b>With Filter</b>	<b>kW</b>			
FWX-2-12037-1KB1Y	0.37	430469	2.3	1
FWX-2-12075-1KB1Y	0.75	430470	4.3	1
FWX-2-22150-1KB1Y	1.5	430471	7	2
FWX-2-22220-1KB4Y	2.2	430472	10.5	2
FWX-2-32040-1KB4Y	4	430477	15	3
<b>380-480V ±10% - 3 Phase Input</b>				
<b>kW Model Number</b>		<b>Part Number</b>	<b>Output Current (A)</b>	<b>Frame Size</b>
<b>With Filter</b>	<b>kW</b>			
FWX-2-14075-3KA1Y	0.75	430412	2.2	1
FWX-2-14150-3KA1Y	1.5	430413	4.1	1
FWX-2-24220-3KA4Y	2.2	430414	5.8	2
FWX-2-24400-3KA4Y	4	430415	9.5	2
FWX-2-34055-3KA4Y	5.5	430416	14	3
FWX-2-34075-3KA4Y	7.5	430417	18	3

### 3. Mechanical Installation

#### 3.1. General

- Store the FWX Drive in its box until required. Storage should be clean and dry and within the temperature range  $-40^{\circ}\text{C}$  to  $+60^{\circ}\text{C}$
- Install the FWX Drive on a flat, vertical, flame-resistant, vibration-free mounting. If higher IP/NEMA ratings are required mount within a suitable enclosure, according to EN60529
- Mount the drive vertically and do not restrict the air flow to the heat sink fins. The drive generates heat. Allow sufficient space around the unit for heat dissipation. Do not mount the drive near heat-radiating elements or in direct sunlight
- The FWX Drive must be installed in a pollution degree 1 or 2 environment
- The IP66/NEMA 4X drive is intended for INDOOR USE ONLY
- Ensure that all terminals are tightened to the appropriate torque setting
- Avoid Condensation build up in the drive. The washdown process of the drive may create a temperature and humidity change in and around the drive. If the unit is mounted in a cool environment and washed down with higher temperature water; as the drive cools to room temperature, condensation can form inside the drive, especially around the display. To prevent this from occurring, avoid using sealed connectors around rubber-coated cables to seal the drive. These do not allow any air transfer and hence create a level of condensation and humidity that exceeds the drive's rating

#### 3.2. Mechanical dimensions and mounting

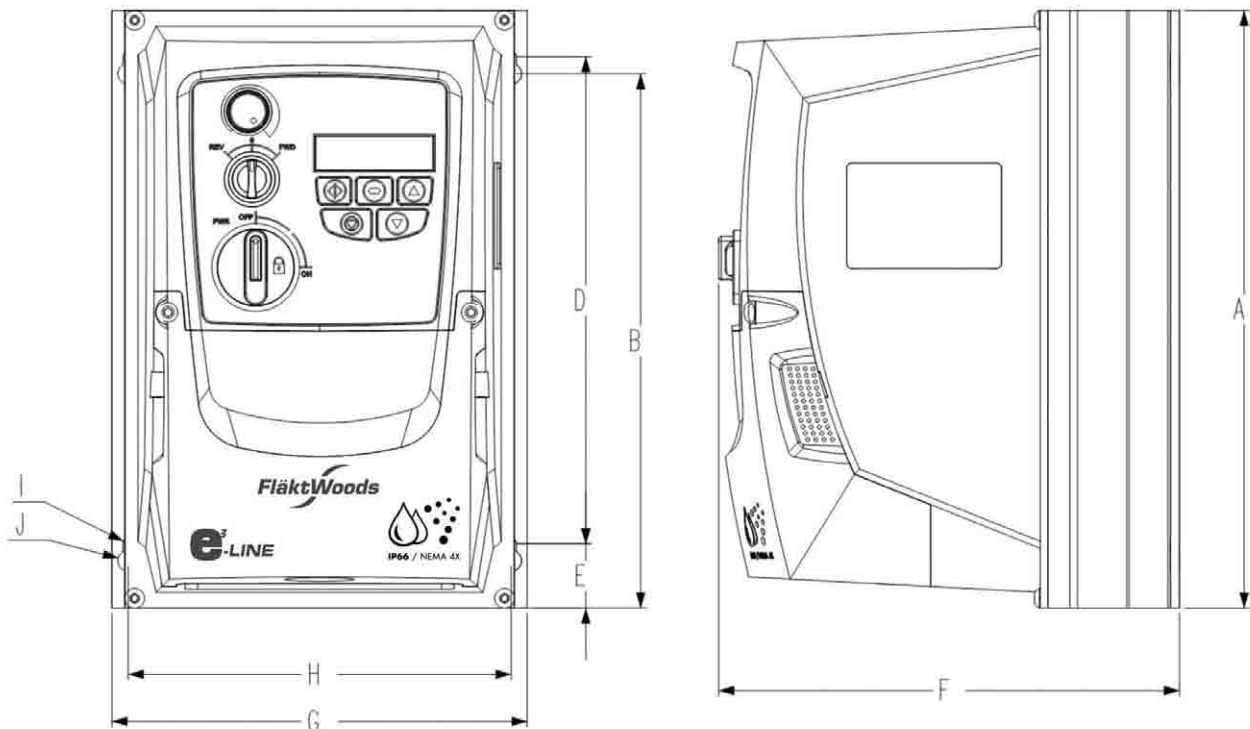

Drive Size	A		B		D		E		F		G		H		I		J	
	mm	in	mm	in	mm	in	mm	in	mm	in	mm	in	mm	in	mm	in	mm	in
1	232	9.13	207	8.15	189	7.44	25	0.98	179	7.05	161	6.34	148.5	5.85	4	0.16	8	0.31
2	257	10.12	220	8.67	200	7.87	28.5	1.12	186.5	7.34	188	7.4	176	6.93	4.2	0.17	8.5	0.33
3	310	12.2	276.5	10.89	251.5	9.9	33.4	1.31	228.7	9	210.5	8.29	197.5	7.78	4.2	0.17	8.5	0.33

Control Terminal Torque Settings of 0.5 Nm (4.5 lb-in)  
 Power Terminal Torque Settings of 1 Nm (9 lb-in)

The IP66/NEMA 4X FWX Drives can be installed side-by-side with their heat sink flanges touching. This gives adequate ventilation space between drives. If the FWX Drive is to be installed above another drive or any other heat-producing device, the minimum vertical spacing is 150mm (5.9 inches) above and below. Mount the drive vertically and do not restrict the air flow to the heat sink fins.

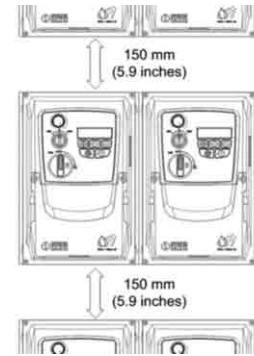

### 3.3. Gland Sizes & Lock off

The use of suitable gland system is required to maintain the appropriate IP / Nema rating. Cable entry holes will need to be drilled to suit this system. Some guidelines sizes are defined below:  
 Please take care when drilling to avoid leaving any particles within the product.

<b>Cable Gland recommended Hole Sizes &amp; types:</b>			
Size 1	22mm	PG13.5	M20
Size 2 & 3	25mm	PG16	M25
<b>Flexible Conduit Hole Sizes:</b>			
Size 1	28mm	3/4 in	21
Size 2 & 3	35mm	1 in	27
• Not intended for rigid conduit system			
<p><b>Power Isolator Lock Off:</b></p> <p>On the switched models the main power isolator switch can be locked in the 'Off' position using a 20mm standard shackle padlock (not supplied).</p> <p>Press the centre of the switch and insert a suitable padlock</p>			

### 3.4. Removing the Terminal Cover

Undo the 2 screws on the front of the product to allow access to the connection terminals.

## 4. Power Wiring

### 4.1. Grounding the Drive

This manual is intended as a guide for proper installation. Fläkt Woods Limited cannot assume responsibility for the compliance or the non-compliance to any code, national, local or otherwise, for the proper installation of this drive or associated equipment. A hazard of personal injury and/or equipment exists if codes are ignored during installation.

Only qualified electrical personnel familiar with the construction and operation of this equipment and the hazards involved should install, adjust, operate, or service this equipment. Read and understand this manual and other applicable manuals in their entirety before proceeding. Failure to observe this precaution could result in severe bodily injury or loss of life.

### 4.1.1. Grounding Guidelines

The ground terminal of each FWX Drive should be individually connected DIRECTLY to the site ground busbar (through the filter if installed). FWX Drive ground connections should not loop from one drive to another, or to, or from any other equipment. Ground loop impedance must conform to local industrial safety regulations. The drive Safety Ground must be connected to system ground. Ground impedance must conform to the requirements of national and local industrial safety regulations and/or electrical codes. The integrity of all ground connections should be checked periodically.

#### Ground Fault Monitoring

If a system ground fault monitor is to be used, only Type B devices should be used to avoid nuisance tripping.

Drives with an EMC filter have an inherently higher leakage current to Ground (Earth).

The FWX Drive product range has input supply voltage surge suppression components fitted to protect the drive from line voltage transients, typically originating from lightning strikes or switching of high power equipment on the same supply.

#### Safety Ground

This is the safety ground for the drive that is required by code. One of these points must be connected to adjacent building steel (girder, joist), a floor ground rod, or bus bar. Grounding points must comply with national and local industrial safety regulations and/or electrical codes.

#### Motor Ground

The motor ground must be connected to one of the ground terminals on the drive.

#### Shield Termination (Cable Screen)

The safety ground terminal provides a grounding point for the motor cable shield. The motor cable shield connected to this terminal (drive end) should also be connected to the motor frame (motor end). Use a shield terminating or EMI clamp to connect the shield to the safety ground terminal.

When shielded cable is used for control and signal wiring, the shield should be grounded at the source end only, not at the drive end.

## 4.2. Wiring Precautions

Connect drive according to section 4.3 ensuring that motor terminal box connections are correct. There are two connections in general: Star and Delta. It is essential to ensure that the motor is connected in accordance with the voltage at which it will be operated. For more information, refer to section 4.4 Motor Terminal Box Connections.

For recommended cabling and wiring sizing, refer to section 7.2 Rating tables.

It is recommended that the power cabling should be 3-core or 4-core PVC-insulated screened cable, laid in accordance with local industrial regulations and codes of practice.

### 4.2.1. IP66/NEMA 4X Switched

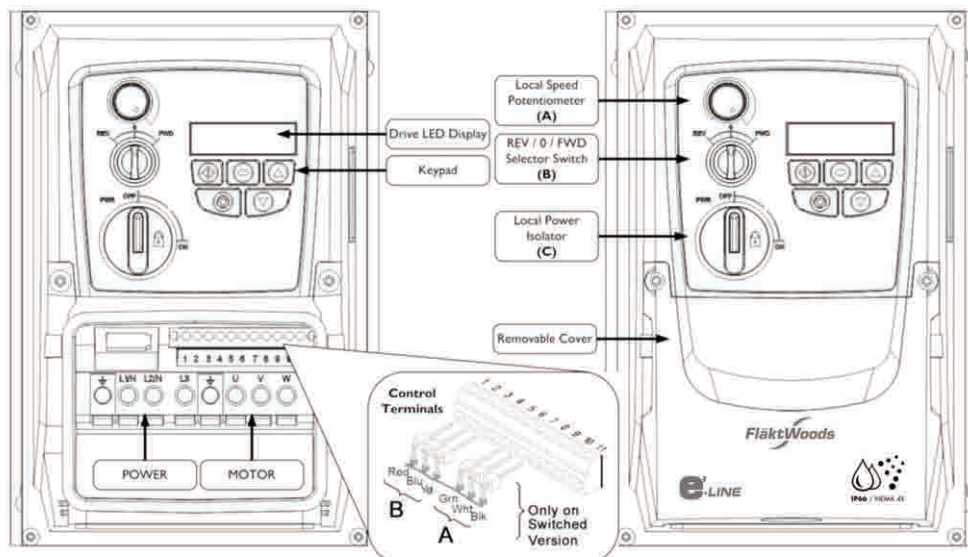

### 4.3. Drive and motor connections





For 1 phase supply power should be connected to L1/L, L2/N.  
 For 3 phase supplies power should be connected to L1, L2, L3. Phase sequence is not important.  
 The Motor should be connected to U, V, W

### 4.4. Motor Terminal Box Connections



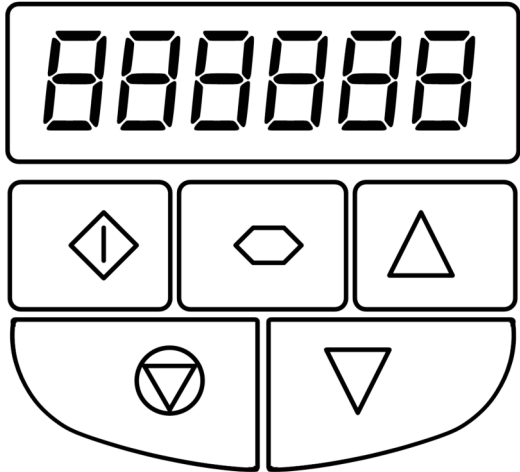



Please refer to the terminal box connection diagram supplied with the fan unit for details.

## 5. Operation





### 5.1. Managing the keypad

	NAVIGATE	Used to display real-time information, to access and exit parameter edit mode and to store parameter changes	
	UP	Used to increase speed in real-time mode or to increase parameter values in parameter edit mode	
	DOWN	Used to decrease speed in real-time mode or to decrease parameter values in parameter edit mode	
	RESET / STOP	Used to reset a tripped drive When in Keypad mode is used to Stop a running drive	
	START	When in keypad mode, used to Start a stopped drive or to reverse the direction of rotation if bi-directional keypad mode is enabled	

#### 5.1.1. Changing Parameters

To change a parameter value press and hold the  key for >1s whilst the drive displays . The display changes to P-01, indicating parameter 01. Press and release the  key to display the value of this parameter. Change to the required value using the  and  keys. Press and release the  key once more to store the change. Press and hold the  key for >1s to return to real-time mode. The display shows STOP if the drive is stopped or the real-time information (e.g. speed) if the drive is running.

#### 5.1.2. Reset Factory Default Settings

To reset factory default parameters, press ,  and  for >2s. The display shows P-def. Press the  button to acknowledge and reset the drive.

### 5.2. Terminal Control

For the purposes of normal speed control changes or connections to the terminal control block (located directly above U V W terminals) are not required.

### 5.3. REV/O/FWD Selector Switch

For the purposes of fan safety the reverse function of the REV/O/FWD selector switch on the fascia of the FWX Drive has been disabled to prevent the fan from being inadvertently run in reverse mode. If reverse operation is genuinely required in addition to normal forward operation then consult Fläkt Woods for advice.

## 5.4. Standard parameters

Par.	Description	Range	Default	Explanation
<b>P-01</b>	Maximum speed	Factory set default	50Hz	Maximum speed limit – Hz or rpm. See P-10
<b>P-02</b>	Minimum speed	0 to P-01 (max 50/60Hz)	10Hz	Minimum speed limit – Hz or rpm. See P-10
<b>P-03</b>	Acceleration ramp time	0 to 600s	10s	Acceleration ramp time from 0 to base speed (P-09) in seconds
<b>P-04</b>	Deceleration ramp time	0 to 600s	10s	Deceleration ramp time from base speed (P-09) to standstill in seconds.
				When P-04=0, the deceleration ramp is set by P-24. Setting P-04=0 also activates dynamic ramp control, where the ramp may be extended automatically to prevent an O-Volt trip.
<b>P-06</b>	Energy Optimiser	0: Disabled	1	When enabled, automatically reduces applied motor voltage on light load. Minimum value is 50% of nominal.
		1: Enabled		
<b>P-07</b>	Motor rated voltage	0, 20V to 250V	230V	Rated (nameplate) voltage of the motor (Volts). Value limited to 250V for low voltage drives. Setting to zero disables voltage compensation
		0, 20V to 500V	400V	
<b>P-08</b>	Motor rated current	25% -100% of drive rated current	Drive rating	Rated (nameplate) current of the motor (Amps).
<b>P-09</b>	Motor rated frequency	50Hz to 60Hz	50Hz	Rated (nameplate) frequency of the motor.
<b>P-10</b>	Motor rated speed	0 to 3600 rpm	0	When non-zero, all speed related parameters are displayed in rpm

## 6. Troubleshooting

### 6.1. Fault messages

Fault CFWX	Description	Corrective Action
<b>P-def</b>	Factory Default parameters have been loaded	Press STOP key, drive is ready to configure for particular application
<b>O-1</b>	Over current on drive output.	Motor at constant speed: investigate overload or malfunction.
	Excess load on the motor.	Motor starting: load stalled or jammed. Check for star-delta motor wiring error.
	Over temperature on the drive heat sink	Motor accelerating/decelerating: The accel/decel time too short requiring too much power. If P-03 or P-04 cannot be increased, a bigger drive is required. Cable fault between drive and motor.
<b>I.t-trp</b>	Drive has tripped on overload after delivering >100% of value in P-08 for a period of time.	Check to see when the decimal points are flashing (drive in overload) and either increase acceleration ramp (P-03) or decrease motor load. Check cable length is within drive specification. Check the load mechanically to ensure it is free, and no jams, blockages or other mechanical faults exist
<b>O1-b</b>	Brake channel over current	Over current in the brake resistor circuit. Check the cabling to the brake resistor. Check the brake resistor value. Ensure minimum resistance values from the rating tables are observed.
<b>OL-br</b>	Brake resistor overload	Brake resistor overload. Increase deceleration time, reduce load inertia or add further brake resistors in parallel. Ensure minimum resistance values from the rating tables are observed.
<b>PS-trp</b>	Internal power stage fault	Check wiring to motor; look for ph-ph or ph-Earth short circuit. Check drive ambient temp, additional space or cooling needed? Check drive is not forced into overload.
<b>O.Volt</b>	Over voltage on DC bus	Supply problem, or increase decel ramp time P-04.
<b>U.Volt</b>	Under voltage on DC bus	This occurs routinely when power is switched off. If it occurs during running, check power supply voltage.
<b>O-t</b>	Heat sink over temperature	Check drive ambient temp. Additional space or cooling required.
<b>U-t</b>	Under temperature	Trip occurs when ambient temperature is less than -10°C. Temperature must be raised over -10°C in order to start the drive.
<b>th-flt</b>	Faulty thermistor on heat sink.	Refer to your Fläkt Woods Authorised Distributor.
<b>E-trip</b>	External trip (on digital Input 2 or 3)	E-trip requested on digital input 2 or 3. Normally closed contact has opened for some reason.
		If motor thermistor is connected check if the motor is too hot.
<b>SC-trp</b>	Comms loss trip	Check communication link between drive and external devices. Make sure each drive in the network has its unique address.
<b>P-LOSS</b>	Input phase loss trip	Drive intended for use with a 3 phase supply has lost one input phase.
<b>SPIn-F</b>	Spin start failed	Spin start function failed to detect the motor speed.
<b>dAtA-F</b>	Internal memory fault.	Parameters not saved, defaults reloaded.
		Try again. If problem recurs, refer to your Fläkt Woods Authorised Distributor.
<b>4-20 F</b>	Analog input current out of range	Check input current in range defined by P-16.
<b>SC-FLt</b>	Internal drive Fault	Refer to your Fläkt Woods Authorised Distributor.
<b>FAULty</b>	Internal drive Fault	Refer to your Fläkt Woods Authorised Distributor.

## 7. Technical data

### 7.1. Environmental

Operational ambient temperature range: -10 ... 40°C (frost and condensation free)

Storage ambient temperature range: -40 ... 60°C

Maximum altitude: 2000m. Derate above 1000m : 1% / 100m

Maximum humidity: 95%, non-condensing

### 7.2. Rating tables

200-240V ±10% - 1 Phase Input – 3 Phase Output

kW	Frame Size	Nominal Input Current	Fuse or MCB (type B)	Supply Cable Size	Nominal Output Current	150% Output Current 60 secs	Motor Cable Size	Max Motor Cable Length	Min Brake Res Value
		Amps	Amps	mm <sup>2</sup>	Amps	Amps	mm <sup>2</sup>	m	□
0.37	1	6.7	6	1.5	2.3	3.45	1.5	25	-
0.75	1	12.5	10	1.5	4.3	6.45	1.5	25	-
1.5	2	19.3	20	4	7	10.5	1.5	100	47
2.2	2	28.8	32(35)*	4	10.5	15.75	1.5	100	47
4	3	35	40	6	15	22.5	2.5	100	47

380-480V ±10% - 3 Phase Input – 3 Phase Output

kW	Frame Size	Nominal Input Current	Fuse or MCB (type B)	Supply Cable Size	Nominal Output Current	150% Output Current 60 secs	Motor Cable Size	Max Motor Cable Length	Min Brake Res Value
		Amps	Amps	mm <sup>2</sup>	Amps	Amps	mm <sup>2</sup>	m	□
0.75	1	2.9	5	1.5	2.2	3.3	1.5	25	-
1.5	1	5.4	10	1.5	4.1	6.15	1.5	25	-
2.2	2	7.6	10	1.5	5.8	8.7	1.5	50	100
4	2	12.4	16(15)*	2.5	9.5	14.25	1.5	50	100
5.5	3	16.1	20	2.5	14	21	2.5	100	22
7.5	3	17.3	20	4	18	27	2.5	100	22

Output Frequency range: 0 - P-01 (500Hz max)

All the drives in the above table are suitable for use on a circuit capable of delivering not more than the above specified maximum short-circuit Amperes symmetrical with the specified maximum supply voltage.

# ***We Bring Air to Life***

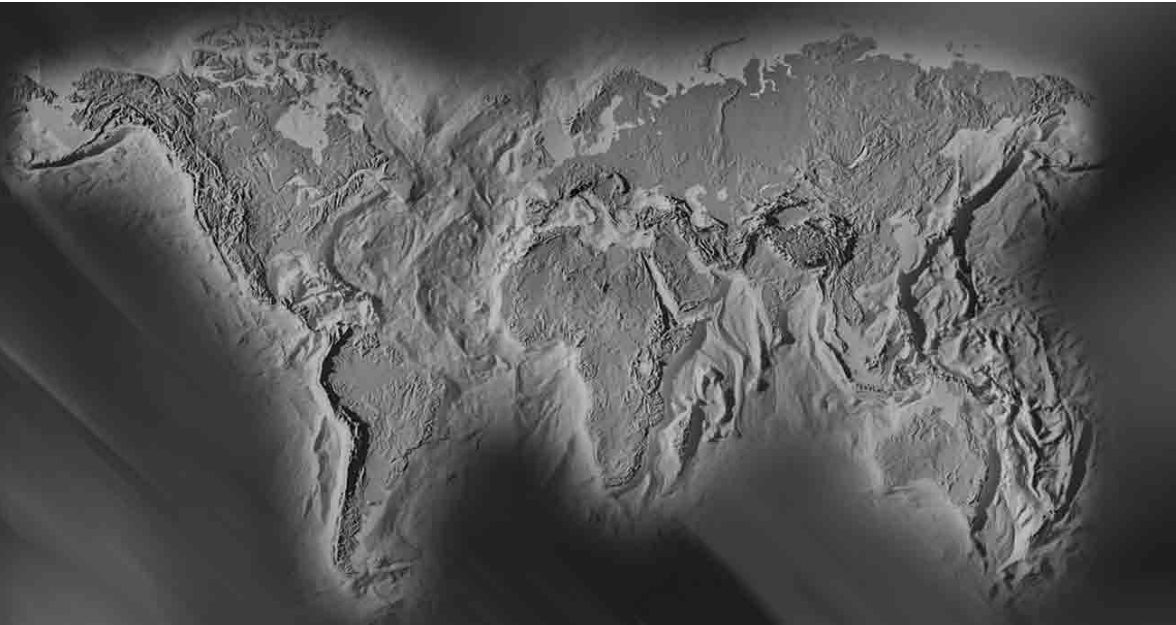

**Fläkt Woods Group provides a full range of products and solutions for buildings ventilation, air treatment and industrial air movement**

## **Sales Office**

### **Fläkt Woods Ltd**

Unit 6240, Bishops Court  
Solihull Parkway  
Birmingham  
B37 7YB  
Tel: +44 (0)121 717 4680  
Fax: +44 (0)121 717 4699

## **Sales Office**

### **Fläkt Woods Ltd**

First Floor, Entrance 6,  
Crossford Court  
Dane Road, Sale, Cheshire  
M33 7BZ  
Tel: +44 (0)161 969 1992  
Fax: +44 (0)161 969 4612

## **Head Office**

### **Fläkt Woods Ltd**

Axial Way  
Colchester  
Essex  
CO4 5ZD  
Tel: +44 (0)1206 222 555  
Fax: +44 (0)1206 222 777

Sales Offices available World Wide - See our website for details

**[www.flaktwoods.co.uk](http://www.flaktwoods.co.uk)**



Due to a policy of continuous development and improvement the right is reserved to supply products which may differ from those illustrated and described in this publication. Certified dimensions will be supplied on request on receipt of order.

Copyright, Fläkt Woods Ltd, 2009.

All rights reserved. No part of this publication may be produced in any material form by any means without the written permission of Fläkt Woods Ltd. Any unauthorised use of this data may result in legal proceedings.