

MiniBox Fan



Safety, Installation, Operation and Maintenance Instructions

SAFETY, INSTALLATION, OPERATION AND MAINTENANCE MANUAL: GENERAL INSTRUCTIONS FOR FLÄKT WOODS LIMITED FANS

1. SAFETY

- 1.1** Only Approved, Qualified personnel familiar with the assessment of hazards and risks associated with fans, and with the use of tools and test equipment required to service such fans, should install, operate and maintain the product.
- 1.2** If the installer or user is unable to understand the information in this manual, or has any doubt that a safe and reliable installation, operation and maintenance of the equipment can be assured, Fläkt Woods Limited or their representative should be contacted for advice.
- 1.3** All warning and safety information contained within this document should be read before working on the fan assembly.
- 1.4** The fan is designed to operate up to the maximum temperature detailed in the electrical information table.
- 1.5** Each fan assembly is delivered with a Declaration of Conformity that should be retained with the fan.
- 1.6** The fan assembly is manufactured specifically to fulfil a particular application/environment. No deviation from the original requirement should be implemented without referring to Fläkt Woods Limited. Should a fan failure occur whilst the product is under warranty, the Fläkt Woods Limited service centre should be contacted, and supplied with full fan nameplate details, before any repair work is undertaken.

2. HANDLING/STORAGE

- 2.1** On receipt of the fan assembly check that it is as ordered. Before fully unpacking the fan check that it has not been damaged during transit (bent flanges, deformed duct, damaged guard/impeller etc). When unpacking to gain access to the fan, care should be taken to avoid injury from sharp edges, burrs, nails, staples, splinters etc. The fan packaging should be considered as a protective device only.
- 2.2** When fan assemblies are retained in storage, access by un-authorised persons must be prevented with the use of guards, barriers or secure premises such that fan assemblies that may be rotating (windmilling) do not present a hazard.
- 2.3** The fan assembly can be heavy and sometimes unwieldy (centre of gravity not central), and should be lifted slowly to prevent damage and distortion. The stored fan assembly must not have equipment stacked on it, and it must not be stacked on other equipment. The packaging must not be used as a lifting device unless otherwise indicated. The fan should be stored in a safe, clean, dry, vibration-free location.
- 2.4** If the fan is to be stored for 12 months or more, an inspection by Fläkt Woods Limited service centre before installation is advised.

3. INSTALLATION (MECHANICAL)

- 3.1** It is recommended that suitable safety guards form part of the installation wherever necessary.
- 3.2** We recommend that an air filter is fitted within the ductwork to reduce the accumulation of dirt on the fan impeller. An excessive build up of dirt could lead to imbalance of the impeller and vibration problems.
- 3.3** Where the fan assembly is delivered packaged, the packaging must be considered as a protective device only, and must not be used as a lifting aid unless otherwise indicated. During lifting all personnel must be clear of the area below the suspended fan.
- 3.4** An airflow indication arrow is shown on the fan nameplate. Sharp bends in the ductwork close to the fan must be avoided. Adequate room must be allowed round the fan for safe inspection and

future maintenance, and the environment must be safe for both the fan, and for personnel.

- 3.5** Care must be taken to ensure that during extremes of wet and windy weather any ingress of water through the fan will not reach sensitive or hazardous areas within the building.
- 3.6** The component parts of the fan assembly, including anti-vibration mounts, flexible connectors (and their clips), weather proofing, platforms, supports, chains and harnesses etc (if fitted), must be fully aligned before being bolted together so that no distortion or stress is placed on the equipment.
- 3.7** Appropriate fixings, with the correct torque applied, must be used to secure the fan into position. The final position of the fan must be strong and rigid enough to take the weight of the fan and any other weight applied during installation.

4. INSTALLATION (ELECTRICAL) AND OPERATION

- 4.1** The fan assembly contains rotating parts and electrical connections, which can be a danger and cause injury. If there is any doubt that a safe and reliable installation of the fan can be assured, Flåkt Woods Limited or their representative should be contacted for advice.
- 4.2** If the fan stops due to an overheat situation, the overheat protection thermostat (if fitted) may reset as the temperature cools and automatically restart the fan if power is still applied.
- 4.3** The fan assembly is fitted with a 1.5m connection lead. All connections should be made by an appropriately qualified electrician. Connection details are provided with the fan assembly. MiniBox units can be connected to the mains via a fused spur/plug. It is good practice to fit a clearly marked lockable isolator switch close to the fan, and have a clearly marked and accessible push button stop/start switch on a control panel located remotely from the fan. The two switches allow safe control of the fan, provide a means of safely isolating the fan (until a controlled restart is made); they protect personnel during maintenance, during a fault situation, or during a mains failure/fluctuation. A suitable earth must also be connected.
- 4.4** Fuses and wiring in the fan electrical control circuit must be sufficiently rated to carry the fan starting current as indicated on the motor nameplate. Fuses should be regarded as only protecting the wiring against the effects of short circuits or earth faults; they are not suitable for overload protection. To provide full protection for the motor, a DOL starter with overload protectors should be used. Overload protectors should be rated 15% above the motor full load current indicated on the motor rating label.
- 4.5** If a speed controller, or other controlling equipment, forms part of the system it should be able to control the fan within safe limits. Sufficient fan speed must be maintained to open any shutters that may be in the airflow. The controlling equipment should be securely located, and should not be, or cause, a radiation hazard. Flåkt Woods Limited can be contacted for advice on all forms of control equipment supplied by the Company.
- 4.6** Speed controllers should not be used without prior agreement with Flåkt Woods Limited. The fans are not suitable for control using a frequency inverter.

5. SWITCH-ON

- 5.1** Only appropriately qualified personnel should switch-on the fan. Before switching on confirm that the electrical supply is fully compliant with the requirement of the motor as detailed on the motor nameplate, that the fan is correctly installed, all component parts and fixings are secure, safety guards are in place and no loose articles are present in the vicinity of the fan.
- 5.2** Immediately on switch-on check the assembly for smooth, low-vibration running, that the current consumption is within the full load current specified on the nameplate, and that the motor is not getting excessively hot. Check that the impeller is rotating in the correct direction. The fan must not be switched on and off in a manner that could cause overheating of the motor, and could damage the insulation of the motor and the wiring to the motor.

6. MAINTENANCE

- 6.1** No maintenance work should be attempted before switching off and completely isolating the fan assembly, and its controls, from all electrical supplies and allowing the rotating parts of the fans to come to rest, the motors to cool and the capacitors to discharge.
- 6.2** It is essential to ensure that all fixings on the assembly are secure.
- 6.3** The complete fan assembly can be easily removed for cleaning purposes. Under no circumstances should the interior space and fan unit be cleaned with water or high-pressure steam
- 6.4** After maintenance ensure that no loose articles are present in the vicinity of the fan, that all safety guards, chains or steel ropes, etc., are properly secured into their original location, and that any temporary device used to stop the fan blades windmilling has been removed.
- 6.5** Information on all aspects of overhaul/extended maintenance is available from Fläkt Woods Limited service centre. After overhaul/extended maintenance the fan assembly must be safely and correctly installed back into its original position in accordance with this document.

7. FAULT-FINDING

- 7.1** Fault-finding must be carried out on the fan assembly by appropriately qualified personnel using the correct tools and equipment.

7.1.1 Electrical

- 7.1.1.1** Isolate the fan and controls from the electrical supply, check that the electrical connections to the assembly are secure and wired in accordance with the circuit diagram,
- 7.1.1.2** Check that the voltage applied to the assembly is as specified on the motor nameplate,
- 7.1.1.3** Connect an ammeter (clampmeter) in line with each phase (one phase in the case of single phase motors) of the motor in turn and check that the current consumption is within the full load current specified on the motor nameplate,
- 7.1.1.4** Isolate the fan and controls from the electrical supply, measure the resistance of each motor winding to earth, and between each winding, using a 500V d.c insulation tester. If the reading is less than ten megohms the reason is liable to be dampness in the motor. To dry the motor place it in a warm (typically 40 degrees centigrade) dry airstream and regularly monitor the motor until the insulation reading is restored to ten megohms or greater. If the reading remains less than ten megohms a break-down in the motor winding insulation could be the reason, and a motor rewind/overhaul may be necessary,
- 7.1.1.5** Ensure that there is no smell of burnt insulation in the vicinity of the motor.

7.1.2 Mechanical

Before any of the following checks checks are made Isolate the fan and controls from the electrical supply.

- 7.1.2.1** Check that there is no obstruction to the motor impeller blade, that the blade is clean, and no loose articles or debris are present in the vicinity,
- 7.1.2.2** Rotate the motor shaft by hand. Investigate any sound of internal chaffing, rubbing or stiffness. Any stiffness may indicate that the bearings require lubrication or replacing,
- 7.1.2.3** Lift the end of the motor shaft if possible to check for bearing wear (i.e. excessive lift of shaft). Rotate the motor shaft by hand. Investigate any sound of internal chaffing or rubbing,
- 7.1.2.4** Ensure that all fixings are secure.

8. DISPOSAL

When the fan assembly has completed its working life the metal components should be segregated and recycled. The remaining items of material should be safely disposed of in accordance with local health and safety regulations.

Product Code	Speed rev/min	Product Number	220-240V/50Hz/1 ϕ			
			Motor Rating [kW]	Full Load Current (at 230V) (A)	Starting Current (at 230V) (A)	Speed Controller Electronic
Mini 100	1980	DH100212	0.095	0.4	0.5	ME1.1
Mini 125	1820	DH125212	0.095	0.41	0.5	ME1.1
Mini 150	1870	DH150212	0.093	0.41	0.48	ME1.1
Mini 200	2500	DH200212	0.094	0.41	0.80	ME1.1
Mini 250	2500	DH250212	0.19	0.83	1.4	ME1.1
Mini 315	2260	DH315212	0.29	1.25	2.0	ME1.3

9. CONNECTION DIAGRAM

Connection Diagram - Minibox & ME/MT1. controller

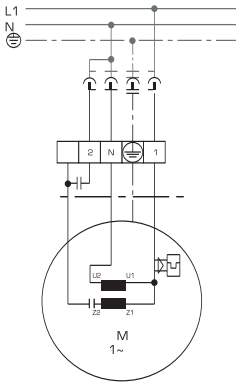

10. INSTALLATION EXAMPLES

Wall Mounted

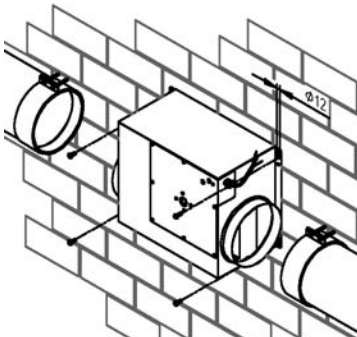

Ceiling Mounted

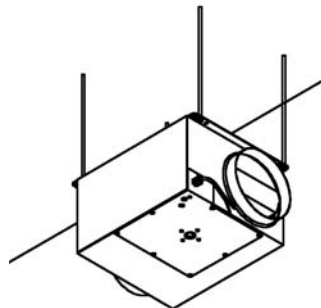

We Bring Air to Life

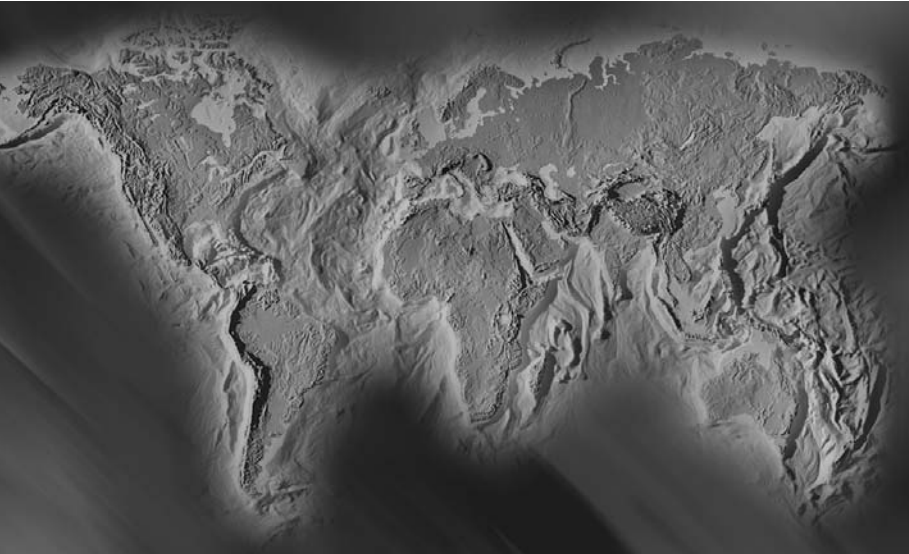

Fläkt Woods Group provides a full range of products and solutions for buildings ventilation, air treatment and industrial air movement

Sales Offices available World Wide - See our website for details

www.flaktwoods.com/uk

Sales Office

Sales Office

Head Office

Fläkt Woods Ltd

Unit 6240, Bishops Court
Soliuhull Parkway
Birmingham
B37 7YB

Tel: +44 (0)121 717 4680

Fax: +44 (0)121 717 4699

Fläkt Woods Ltd

First Floor, Entrance 6,
Crossford Court
Dane Road, Sale, Cheshire
M33 7BZ

Tel: +44 (0)161 969 1992

Fax: +44 (0)161 969 4612

Fläkt Woods Ltd

Axial Way
Colchester
Essex
CO4 5ZD

Tel: +44 (0)1206 222 555

Fax: +44 (0)1206 222 777

Due to a policy of continuous development and improvement the right is reserved to supply products which may differ from those illustrated and described in this publication. Certified dimensions will be supplied on request on receipt of order.

Copyright, Fläkt Woods Ltd, 2007.

All rights reserved. No part of this publication may be produced in any material form by any means without the written permission of Fläkt Woods Ltd. Any unauthorised use of this data may result in legal proceedings.